



HCS2 1201-30

Die neue
I-Kopf-Maschinen-
Generation von  HAPPY

The new generation
of the I-head  HAPPY
Embroidery-Machine



HCS2 1201-30



Farbiges LCD Touch Screen Control Panel



Stickfeld-Beleuchtung



Editierfunktion



Standard LAN Verbindung



PC Verbindung
Serial, USB, LAN



Laser-Marker (Optional)



Kappenrahmen (Optional)

SPEZIFIKATIONEN/SPECIFICATIONS

Modell/Type: HCS2 1201-30		Tech. Daten/Size
Stickfeld	Embroidery area	290 x 285 mm
Kappenrahmen weit	Cap frame wide	290 x 67 mm
Kappenrahmen low-profile	Cap frame low-profile	180 x 67 mm
Max. Freiarm-Rahmen	Largest tubular frame	320 x 320 mm
Nadelanzahl	Number of needles	12
Max. Geschwindigkeit	Max. speed	1000 St./Min.
Speicher	Memory	2.000.000 St.
Muster einlesen vom USB-Stick	Design reading from usb-stick	
Laser Pointer	Laser positioning marker	
Stromverbrauch	Power consumption	220 W
Gewicht	Weight	42 kg

Modell/Type: HCS2 1201-30		Maße/Size
Länge	Length	642 mm
Breite	Width	745 mm
Höhe	Height	734 mm

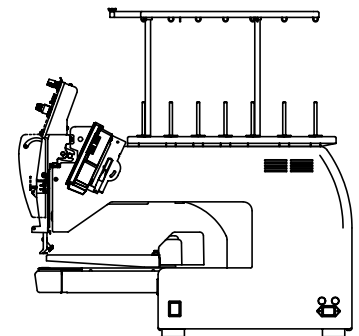
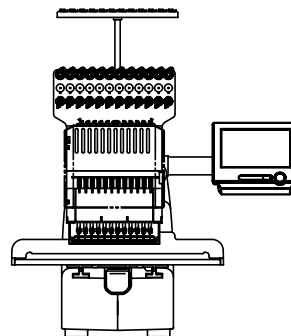

forvex

info@forvex.at

Tel.: +43 676 3060 352